

Luggin's capillary in studying the effect of electrochemical reaction on mechanical properties of solid surfaces

E. D. SHCHUKIN

The Johns Hopkins University, Baltimore, MD, USA

I. V. VIDENSKY, I. V. PETROVA

Institute for Physical Chemistry of the Russian Academy of Sciences, Moscow, Russia

In order to study the mechanism of the electrochemical polarization and active components reduction influence on the mechanical properties of surfaces, a new method has been developed: microscratching of the sample surface under polarization conditions in an electrochemical cell, with continuous monitoring potential in the area adjacent close to the moving indenter. Essential changes in this potential are observed during indenter movement, corresponding with the high activity of the newly formed surface. The very edge of the surface with a groove, where the hard stressed state is combined with accessibility to the medium state, appears to be the most sensitive to this action. This allows one to observe effects of hydrogen embrittlement and active metal cation reduction in the contact zone.

1. Introduction

The technology of novel, high strength and hard materials creates theoretical and practical problems. The most important are: optimization of machining, increasing effectiveness, achievement of high quality of a treated surface, elimination of residual (especially tensile) stresses in subsurface layers, and decreasing tool wear. It was shown that reasonable use of complex physico-chemical surface phenomena can serve as a key and at times a decisive factor [1].

Mechanical properties of solids and materials can dramatically change under the influence of some definite surface-active surrounding media [2, 3]. This concerns, particularly, thin layers adjacent to the surface [4, 5]. Mechanisms and manifestations of such effects are very diverse. Environmental sensitivity can result in the (reversible) decrease in the free surface energy of a solid phase and, correspondingly, in the work of fracture; due to contact with a physico-chemically "akin" liquid phase, and/or adsorption (chemisorption) of surface-active components from the ambient medium, i.e. the Rebhinder effect itself. Environmental influences also include various chemical, electrochemical and catalytical interactions [6–8]. Depending upon the complexity of the conditions, a decrease of resistance either to fracture (embrittlement, comminution facilitation) or to deformation (plasticizing effect) can result. It is important to stress that in all cases considered, the *simultaneous action* of mechanical stresses and active medium is a common condition [9], principally different from dissolution, corrosion in aggressive media, or from routine electrochemical treatment of metals.

All such effects find broad practical applications. Earlier, it was mostly an intuitive-empirical approach; recently a more scientifically based one. This latter approach is used in controlling friction, wear and lubricant action, in lubricant-cooling liquids in mechanical treatment by cutting and by pressing, hardness reducers in rock drilling, facilitating comminution and fine grinding processes [10–13].

Until recently, major attention was paid to the relatively "weak" or "moderate" surface interactions. However, it has been demonstrated that stronger effects can also be used, e.g. dramatic embrittlement, decrease in strength of metals and alloys when in contact with corresponding ("akin") liquid metal phase, can facilitate machining of extremely hard materials [1, 14]. Fig. 1 compares drilling of highly tempered steel with a hard alloy drill (depth versus time) in usual lubricant-cooling media, Fig. 1a, and in a small amount of liquid eutectic zinc-tin, Fig. 1b. Recently, it has been found that the liquid phase can be substituted with a minimum amount of active component (down to monolayer), under reduction conditions on the treated surface in the corresponding electrochemical cell [15, 16]. Fig. 2 shows the effectiveness of such a method used for tempered steel grinding with a corundum wheel: amount of material removed during 2 h grinding versus the density of the current through the treated surface in solutions containing Zn^{2+} and Cd^{2+} ions.

These effects wait for their broad applications, and create, alongside, a number of principal, fundamental problems, which one is obligated to resolve in order to understand the physico-chemical mechanisms of the

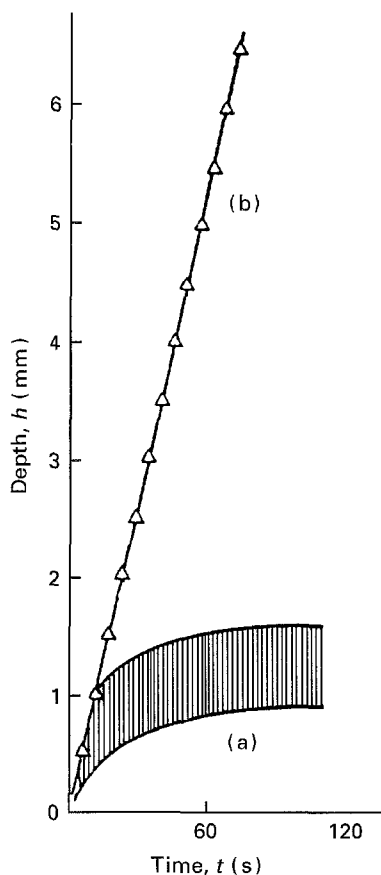

Figure 1 Effectiveness of drilling depth, h , of the drill (hard alloy WC-Co) immersing into tempered steel U-8 versus time, t : in various routine lubricant-cooling liquids and in inactive liquid metals (a) blunting of a drill, and in (b) Zn-Sn eutectic [1].

environmental effects, especially on the microlevel. This is *condicio sine qua non* for the reasonable choice of optimum conditions. A very important role belongs to the development of a novel experimental method, allowing one to observe the influence of an ambient medium on deformation and fracture processes in the thinnest subsurface layers of a solid, just during (*in statu nascendi*) new surface formation, namely where and when it takes place. In such experiments it is expedient to use a combination of conditions *a priori* known as the "most severe", i.e. hard stressed state, arising from the juvenile cells of a surface, and their accessibility for the medium. It has to be mentioned that the very finely elaborated and precise indentation technique, both micro and nanoindentation, does not correspond to these challenges. A favourable combination of conditions takes place during the cutting processes, particularly in drilling [1, 14]. However, observations in the zone of contact material-tool are connected with difficulties. Some studies are known using an electrode as a local sensor [17, 18]; usually, such measurements were provided later after new surfaces had arisen.

The authors believe the microscratching method opens excellent opportunities, particularly in the version of *ultramicrosclerometry* developed by Savenko [19] in our laboratory. This method allows one to observe transitions from elastic behaviour in the surface layer to plastic (starting with the appearance of the very first dislocations along the indenter trace),

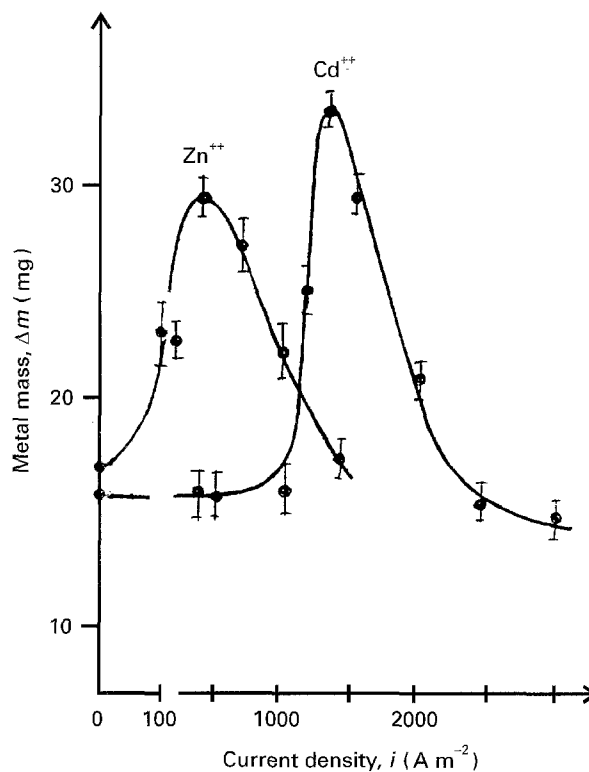

Figure 2 The mass, Δm , of metal (tempered steel U-8) removed following grinding for 2 h, at different current densities, i , in 10% ZnSO₄ and in 10% CdSO₄ solutions [15].

and then to brittle fracture (nucleation and growth of the first microcracks). Such transitions, the level of the damagability of the surface, and the medium influence have been supplied with quantitative characteristics, on the basis of the statistical method developed for this purpose [20].

In a recent study, new approaches were proposed. Firstly, involving Luggin's microelectrode, moving immediately after an indenter. Secondly, special attention is paid to the changes in material just on the edge of the groove. High shear components (and, generally speaking, also tensile ones) of the stressed state tensor take place here. Namely, in this area, in the course of surface interatomic bond rupture and reconstruction, these bonds and newly arising cells of the surface are accessible to the molecules (atoms, ions) of the medium. Corresponding methods developed in the laboratory at the Institute for Physical Chemistry, Russian Academy of Sciences, are described below and the first experimental results are presented.

2. Experimental procedure

The experimental device (Fig. 3) consists of an apparatus for microscratching, an electrical circuit for applying potential to the sample in the electrochemical cell, and a circuit for measuring potential changes in the sample-indenter contact zone.

Sample 1, with the ground surface, is placed in an electrochemical cell, 2. Cathode polarization of the sample was used in this series of experiments; the platinum electrode served as an anode, 3. A potentiostat, 4, was used in the potentiostatic regime,

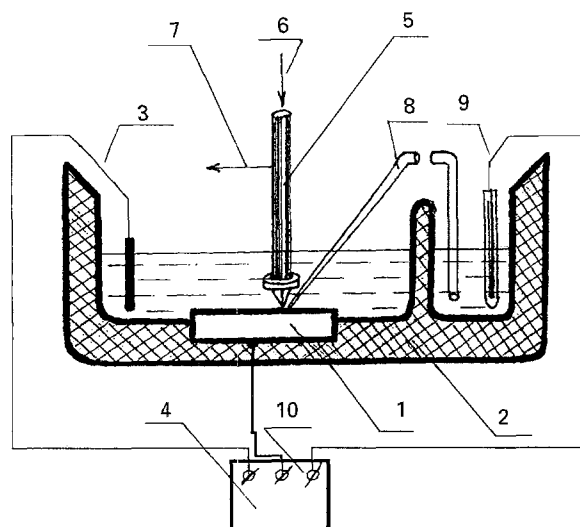

Figure 3 Scheme of the device for studying surface potential changes in the course of microscratching: (1) sample (cathode), (2) electrochemical cell, (3) anode, (4) potentiostat, (5) indenter, (6) direction of the load, (7) direction of indenter movement, (8) Luggin's microelectrode, (9) reference electrode, (10) measuring circuit.

i.e. a constant current was maintained and, correspondingly, a constant current density, i , through the sample surface.

The indenter, 5, with a diamond pyramid (angle at the tip equals 120°), under a constant vertical load, P , 6, was moved horizontally (in the direction, 7, with a face ahead), with a constant velocity, V .

In the immediate neighbourhood of the indenter (at a distance approximately 1 mm), the tip of Luggin's microelectrode, 8, was placed moving after the indenter in the course of scratching. A standard silver-silver chloride electrode, 9, served as a reference. During the experiment, the local changes in potential were monitored, with the help of a potentiostat measuring circuit, 10. Values obtained were reduced to the normal hydrogen electrode.

At the same time, the scanning electron microscope (SEM) observations were carried out on the samples' surfaces in the zone of indenter trace.

3. Results and discussion

Low carbon tempered steel U8A (HRC 60) ground plates were used as samples. The quality of the treatment of the working surface of samples corresponded to the 14th class ($R_a < 0.02$ m cm).

The load on the indenter used in the described series of tests was $P = 20$ g; the velocity of horizontal movement of the indenter was $V = 10$ mm min^{-1} ; the length of the trace (groove) was about 3 mm.

As in earlier experiments with electrochemical-mechanical treatment [15, 16], the authors started with cathode polarization of the sample; hydrogen ions were reduced on its surface. A 0.1 N NaOH solution served as the electrolyte; current density (mean) through the surface of the sample was $i = 50$ A m^{-2} . The changes of surface potential in the zone of contact between the sample and indenter were com-

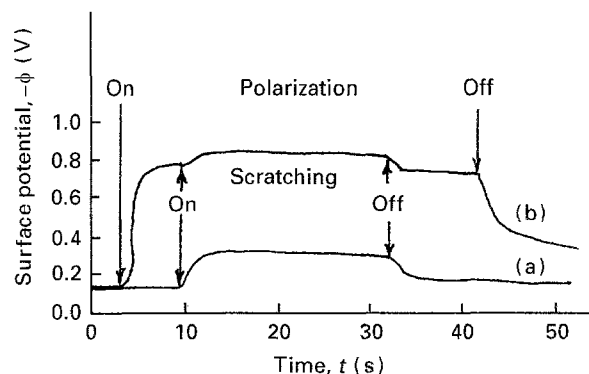

Figure 4 Surface potential changes in the vicinity of indenter: caused by scratching in the absence of an electrical current (a), and due to the combined effect of indenter movement and current through the surface 50 A m^{-2} (b).

pared: when the indenter did not move and when it did; in the absence of a current through the surface of the sample and under a given constant current density.

As an example, in Fig. 4 (curve a) such potential changes versus time are shown in the absence of a current through the sample. The initial part of the curve was obtained when the indenter was resting: the leap increase, for the beginning of its movement, and the reverse drop (approximately) to the initial value, when it stopped again. Curve b in Fig. 4 represents the dependence of the potential versus time under conditions of both indenter movement and cathode polarization of the surface (current density 50 A m^{-2}).

These data witness essential material damages in the contact zone under the indenter (disequilibrium state, increase in chemical activity), and allows one to approach their quantitative characterization.

Comparison of this data with SEM observations of material damages in the zone of the indenter trace is of special interest. Typical pictures are given in Fig. 5: in the absence of a current through a sample (Fig. 5a), and under conditions of constant current density, 50 A m^{-2} (Fig. 5b).

When cathode polarization is applied, i.e. under conditions of hydrogen educing, severe damage of the surface is observed, especially on the very edge of the surface near the groove, when and where the hard stressed state is accompanied by accessibility of the material to an ambient medium.

In this case, such behaviour can be characterized as a sharp, local decrease in the strength and the embrittlement of steel, compared with the plastic mode of a groove in the absence of a current through the surface of a sample. In its turn, the reason for such changes can be considered as local hydrogen embrittlement of the steel, under combined action of mechanical stresses and educed hydrogen playing a role of strong surface-active component.

Due to the new opportunities opened by the described method, one can now apply it to studies of the influence of other active components in the course of electrochemical educing on the surface of a sample.

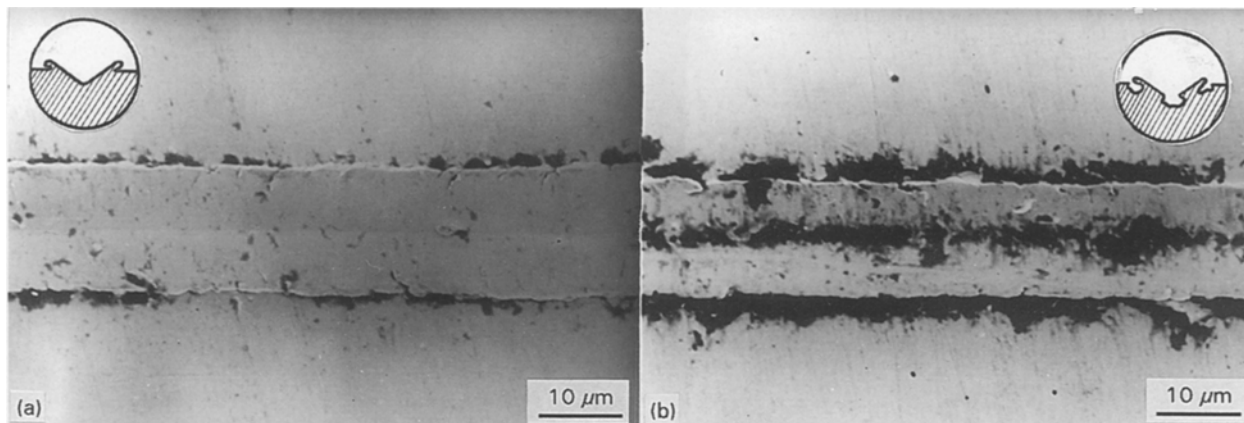

Figure 5 SEM images of grooves after scratching the sample with a load of 20 g: without polarization (a), and due to the combined effect of scratching and electrical current through the surface 50 A m^{-2} (b); schemes of corresponding groove cross-sections are shown in circles.

Acknowledgements

This work is supported in part by the Oak Ridge National Laboratory, Martin-Marietta Laboratories and an MLE grant from the International Science Foundation. The authors thank Drs P. Blau, John Green, Robert Green, C. Liu, V. Savenko and A. Westwood for fruitful discussion, and Mrs M. Weaver for help in preparing the manuscript.

References

1. E. D. SHCHUKIN. *Vestnik AN SSSR* **N11** (1973) 30.
2. P. A. REHBINDER and E. D. SHCHUKIN. *Progress Surface Sci.* **3** (1972) 97.
3. A. R. C. WESTWOOD and N. S. STOLOFF (Eds), "Environment-Sensitive Mechanical Behavior" (Gordon and Breach, New York, 1966).
4. R. M. LATANISION and J. T. FOURIE (Eds), "Surface Effects in Crystal Plasticity" (Noordhoff, Leyden, 1977).
5. E. D. SHCHUKIN, L. A. KOCHANOVA and V. I. SAVENKO. *Advances Mech. Phys. Surf.* **1** (1981) 111.
6. A. R. C. WESTWOOD, J. S. AHEARN and J. J. MILLS. *Colloids & Surf.* **2** (1981) 1.
7. E. D. SHCHUKIN, L. A. KOCHANOVA and V. I. SAVENKO. *Modern Aspects Electrochem.* **24** (1993) 245.
8. E. D. SHCHUKIN, S. I. KONTOROVICH and B. V. ROMANOVSKY. *J. Mater. Sci.* **28** (1993) 1937.
9. E. D. SHCHUKIN, in "Surface Effects in Crystal Plasticity", edited by R. M. Latanision and J. T. Fourier (Noordhoff, Leyden, 1977) p. 701.
10. P. A. REHBINDER, L. A. SCHREINER and K. F. ZHIGACH "Hardness Reducers in Drilling" (Academy Science, USSR, Moscow, 1944, in Russian); English translation Council for Science and Industry Research, Melbourne, 1948.
11. S. Y. VEILER and V. I. LICHTMAN, "Deistvie Smazok pri Obrabotke Metallov Davleniem" (AN SSSR Publishers, Moscow, 1960).
12. A. R. C. WESTWOOD and J. J. MILLS, "Surface Effects in Crystal Plasticity", edited by R. M. Latanision and J. T. Fourier (Noordhoff, Leyden, 1977) p. 835.
13. R. M. LATANISION, K. C. NIELSEN and R. KIRCHBAUM, *Modern Machine Shop* **2** (1974) 69.
14. E. D. SHCHUKIN, Z. M. POLUKAROVA, V. S. YUSHCHENKO, L. S. BRYUKHANOVA and P. A. REHBINDER, *Doklady (Proceedings) AN SSSR* **205** (1972) 86.
15. I. V. VIDENSKY, I. V. PETROVA and E. D. SHCHUKIN. *Kolloidn. Zhurn.* **54** (1992) 19.
16. *Idem*, *J. Mater. Res.* **8** (1993) 2224.
17. N. D. TOMASHOV, Y. S. RUSKOV and I. V. VLASOV. *Zashchita Metallov.* **9** (1973) 250.
18. V. I. POKHMURSKY, "Korroziionnaya Ustalost' Metallov." (Metallurgia, Moscow, 1985).
19. L. A. KOCHANOVA, V. M. KUCHUMOVA, V. I. SAVENKO and E. D. SHCHUKIN, *J. Mater. Sci.* **27** (1992) 5516.
20. E. D. SHCHUKIN, V. I. SAVENKO and L. A. KOCHANOVA, in "Physical Chemistry of the Solid State: Applications to Metals and their Compounds", edited by P. Lacombe (Elsevier, Amsterdam, 1987) p. 47.

Received 28 June
and accepted 14 November 1994